

Compact Disc Player

Operating Instructions



CDP-C910

WARNING

To prevent fire or shock hazard, do not expose the unit to rain or moisture.

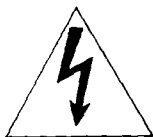
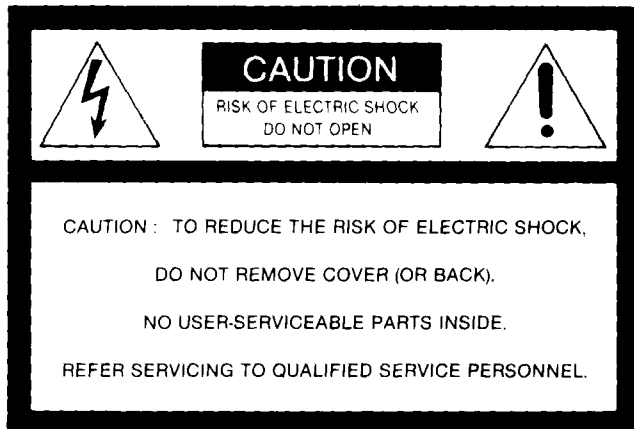

This symbol is intended to alert the user to the presence of uninsulated "dangerous voltage" within the product's enclosure that may be of sufficient magnitude to constitute a risk of electric shock to persons.



This symbol is intended to alert the user to the presence of important operating and maintenance (servicing) instructions in the literature accompanying the appliance.

For the customers in Australia

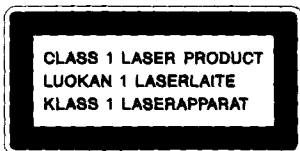

This Compact Disc player is classified as a CLASS 1 LASER product. The CLASS 1 LASER PRODUCT label is located on the rear exterior.

INFORMATION

This equipment generates and uses radio frequency energy and if not installed and used properly, that is, in strict accordance with the manufacturer's instructions, may cause interference to radio and television reception. It has been type tested and found to comply with the limits for a Class B computing device in accordance with the specifications in Subpart J of Part 15 of FCC Rules, which are designed to provide reasonable protection against such interference in a residential installation. However, there is no guarantee that interference will not occur in a particular installation. If this equipment does cause interference to radio or television reception, which can be determined by turning the equipment off and on, the user is encouraged to try to correct the interference by one or more of the following measures:

Reorient the receiving antenna

Relocate the equipment with respect to the receiver

Move the equipment away from the receiver

Plug the equipment into a different outlet so that equipment and receiver are on different branch circuits.

If necessary, the user should consult the dealer or an experienced radio/television technician for additional suggestions. The user may find the following booklet prepared by the Federal Communications Commission helpful:

"How to identify and Resolve Radio-TV interference Problems".

This booklet is available from the U.S. Government Printing Office, Washington, DC 20402, Stock No. 004-000-00345-4.

Owner's Record

The model and serial numbers are located at the rear.

Record these numbers in the spaces provided below.

Refer to these numbers whenever you call upon your Sony dealer regarding this product.

Model No. CDP-C910 Serial No. _____

Table of Contents

Warning	2
Introducing this CD player	3
Installation	4
Precautions	4
Connections	5
Location of controls	6
Front panel	6
Remote commander	7
Preparing the remote commander	7
Installing batteries	7
Setting up the disc magazine	8
Playing a disc – Continuous play	9
Information display	10
Selecting a desired disc	11
Locating a particular selection	11
Locating a particular point in a selection	11
Playing in a random order – Shuffle play	12
To play only the desired discs in a random order – Select shuffle play	12
Playing repeatedly – Repeat play	13
Playing in a desired order – Program play	14
Designating the playing time – Program edit	14
Checking the programmed selections	15
Clearing the programmed selections	15
Designating the total playing time – Time edit	16
Convenient features for tape recording	18
Fading in/Fading out	18
Fading out after a desired duration – Time fade	18
Locating the loudest portion of the disc – Peak search	19
Playing the beginning of each selection – Music scan	20
On custom files	21
Assigning names to a disc – Disc memo	22
Displaying the memos	23
Clearing the disc memo	23
Keeping the program in memory – Bank	24
Memorizing a bank	24
Playing the disc using the bank	24
Clearing the bank	24
Preset the desired output level to a disc – Level file	25
Clearing the level file	25
Timer activated playing	26
Activating the power with an audio timer	26
Maintenance	27
Specifications	27
Troubleshooting guide	back cover

Introducing This CD Player

This unit is equipped with an automatic disc changer which allows you to play up to 10 discs in a row. You can choose from a large number and wide variety of selections.

Enjoy listening in various playing modes

You can select the playing modes among the following:

- Continuous play (page 9) – The entire disc(s) is played once.
- Shuffle play (page 12) – Selections are played in a random order.
- Program play (page 14) – Selections are played in your desired order.
- Repeat play (page 13) – Selections or portions are played repeatedly.

Editing your own tapes

- You can fade the play in or out when making your own tape recording. – Fading in/Fading out (page 18)
- You can confirm the total playing time while choosing the selections to be programmed. – Program edit (page 14)
- The player can program selections automatically to fit in a desired duration. – Time edit (page 16)
- You can stop the play, fading out at the time desired. – Time fade (page 18)
- The loudest portion of the disc will be determined and played repeatedly. – Peak search (page 19)

Making your disc custom-made – CUSTOM FILE function

- You can assign a name to a disc, such as the title of the disc or the date of purchase. – Disc memo (page 22)
- You can store the programmed playing order for a disc. – Bank (page 24)
- You can store the optimum playback level of each disc in the unit's memory. – Level file (page 25)

You can play a beginning of each selection – Music scan

You can check the selections by scanning the beginning of each selection in the disc. You can use this function in any play mode. (page 20)

The easy-to-use disc magazine

Allows you to play a particular set of discs at any time simply by inserting the disc magazine into the CD player. Additional magazines (optional) allow you to create a wide variety of sets.

Easy-to-see display

The selection number, the playing time and the remaining time are displayed by pressing the TIME/MEMO button. And also playing modes like repeat, shuffle, program and bank are displayed in the display window.



This indicates a function operated only from the remote commander.



This indicates a function operated only on the main unit.

Installation

Notes on Installation

Place the unit in a location with adequate air circulation to prevent internal heat build-up in the unit.

This way.

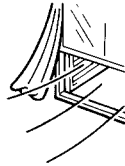
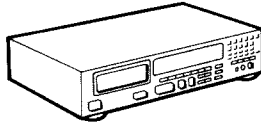

Do not place the unit on a soft surface, such as a rug that would block the ventilation holes on the bottom.

Not this way.

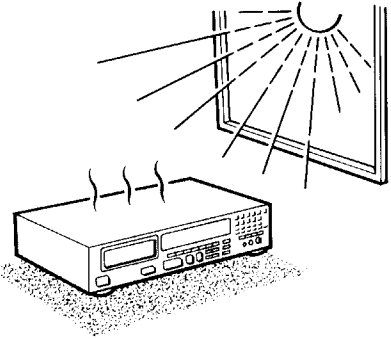
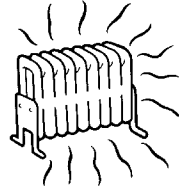

- Do not install the unit:
 - near heat sources such as radiators or air ducts.
 - in a place subject to direct sunlight, excessive dust, mechanical vibration shock.
- Do not move the unit while the disc magazine is inside, otherwise the discs may fall out of the magazine and you will be unable to remove them.

On moisture condensation

If the player is brought directly from a cold to a warm location, or is placed in a very damp room, moisture may condense on the lens inside the unit. Should this occur, the player will not operate. In this case, remove the disc and leave the player turned on for about an hour until the moisture evaporates.

Precautions

On Safety

- Check the unit's operating voltage before operation. It must be identical with that of your local power supply.
- Should any liquid or solid object fall into the cabinet. Unplug the unit and have it checked by qualified personnel before operating it any further.
- Unplug the unit from the wall outlet if it will not be used for a long time. To disconnect the cord, pull it out by grasping the plug. Never pull the cord itself.
- As the laser beam used in this compact disc player is harmful to the eyes, do not attempt to disassemble the cabinet. Refer servicing to qualified personnel only.

On operation

When the unit is not used, turn the power off to conserve energy and to extend the useful life of your unit.

Important

Since the CD system boasts a wide dynamic range, the peaks of high level inputs are recorded with high fidelity, and the noise level is very low. Do not turn up the volume while listening to a portion with no audio signals or very low level inputs if you do, the speakers may be damaged when a peak level portion is played.

For detailed safety precautions, see the leaflet "IMPORTANT SAFEGUARDS".

If you have any questions or problems concerning your unit, please contact your nearest Sony dealer.

Connections

For Correct Connections

- Turn off the power of each unit before making connections.
- Connect the AC power cord last.
- Be sure to insert the plugs firmly into the jacks. Loose connection may cause hum and noise.
- Leave a little slack in the connecting cord to allow for inadvertent shock or vibration.
- Cord plugs and jacks are color coded: Red plugs and jacks are for the right channel (R) and white ones for the left channel (L).

To Connect to an Amplifier

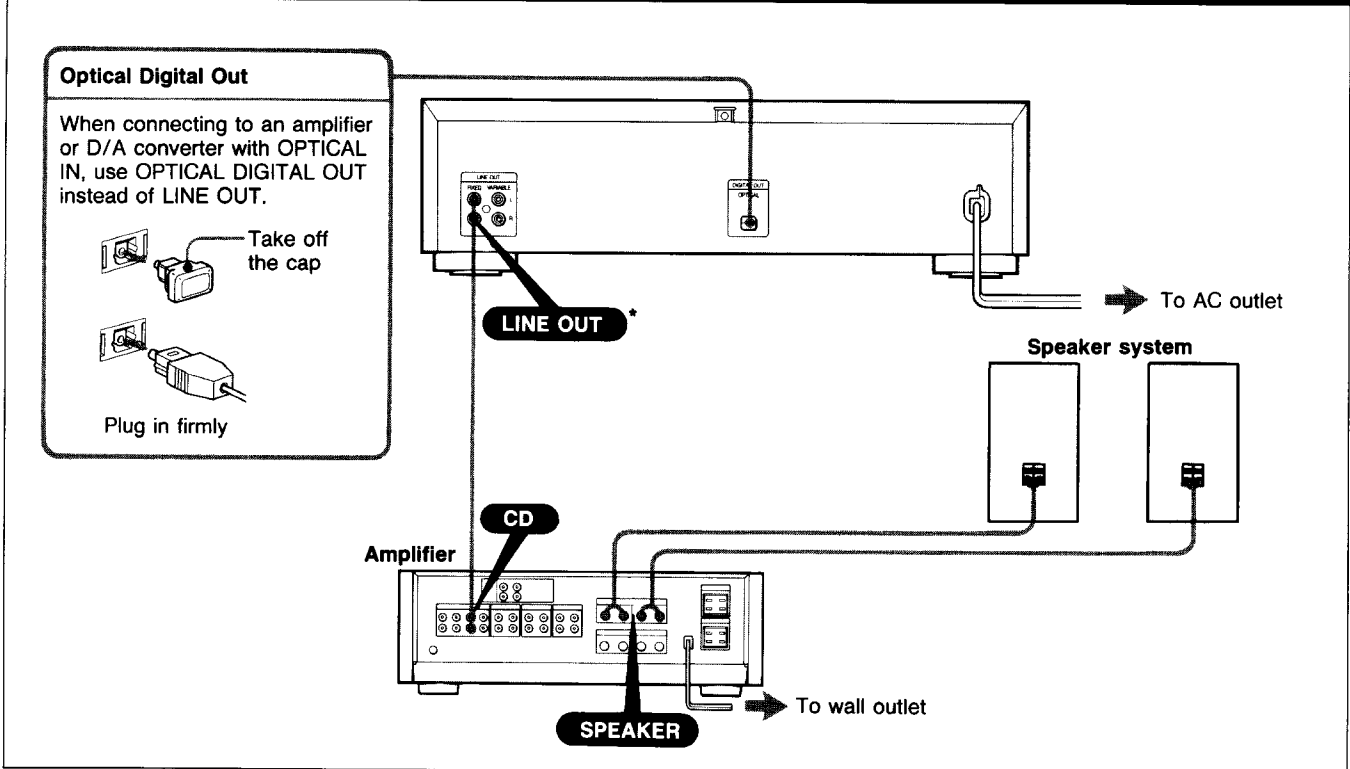

*Notes on LINE OUT

FIXED: The output level is fixed.

VARIABLE: The output level can be adjusted with PHONE LEVEL/LINE OUT LEVEL control or LINE OUT LEVEL buttons on the remote commander. However, if the PHONE LEVEL/LINE OUT LEVEL control is turned while recording, the recording level will change even when it is preset on the tape deck.

Note on optical digital out

Connect the optical out to the amplifier with the optical input or D/A converter. When you connect, use the connecting cable for optical out POC-15 (not supplied). When the optical out is connected, you cannot use fade out, fade in and time fade function.

Location of Controls

Front Panel

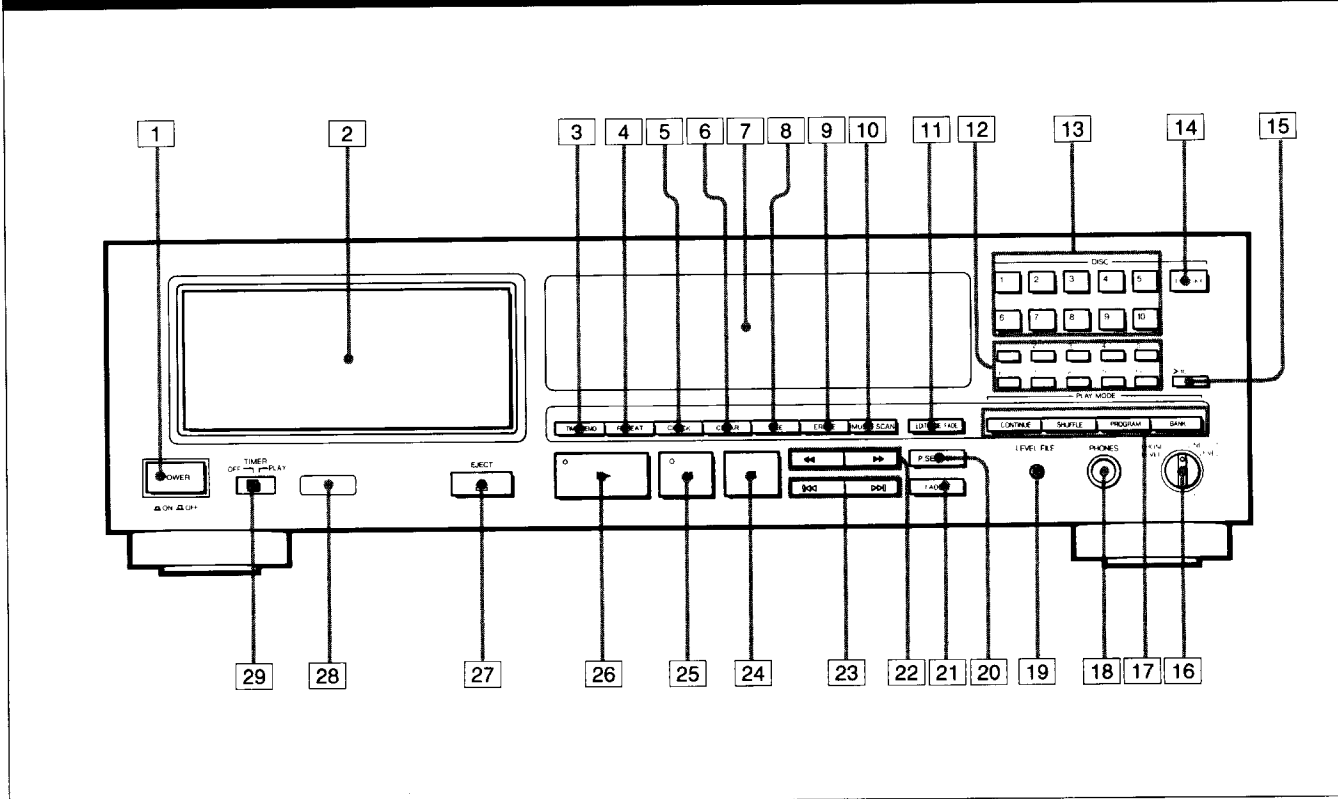

Refer to the pages indicated in ● for details.

- | | |
|----------------------------------|---|
| 1 POWER switch ● | 16 PHONE LEVEL/LINE OUT LEVEL control ● ● |
| 2 Magazine slot ● | 17 PLAY MODE buttons |
| 3 TIME/MEMO button ● | CONTINUE button ● |
| 4 REPEAT button ● | SHUFFLE button ● |
| 5 CHECK (program check) button ● | PROGRAM button ● |
| 6 CLEAR (program clear) button ● | BANK button ● |
| 7 Display window ● | 18 HEADPHONES jack |
| 8 FILE button ● | 19 LEVEL FILE button ● |
| 9 ERASE button ● | 20 P(peak).SEARCH button ● |
| 10 MUSIC SCAN button ● | 21 FADER button ● |
| 11 EDIT/TIME FADE button ● ● | 22 ◀▶▶▶ (manual search) buttons ● |
| 12 Track buttons ● | 23 ◀◀▶▶ (AMS*) buttons ● |
| 13 DISC selectors ● | 24 ■ (stop) button ● |
| 14 DISC SKIP button ● | 25 (pause) button/indicator ● |
| 15 > 10 (over 10) button ● | 26 ▶ (play) button/indicator ● |
| | 27 ▲ EJECT button ● |
| | 28 Remote sensor |
| | 29 TIMER switch ● |

* AMS is the abbreviation of Automatic Music Sensor.

Remote Commander

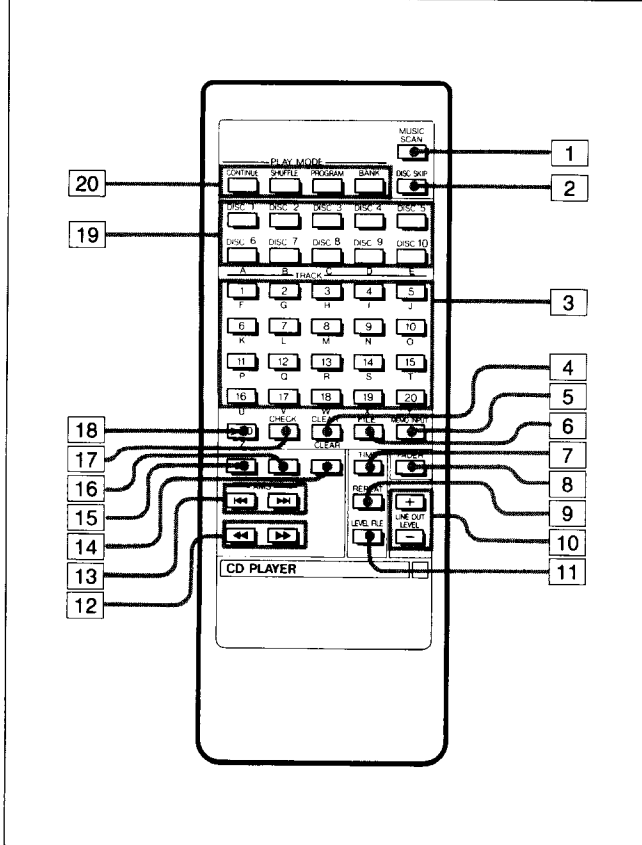

Refer to the pages indicated in ● for details.

- 1 MUSIC SCAN button ●
- 2 DISC SKIP button ●
- 3 Track buttons ●
- 4 CLEAR (program clear) button ●
- 5 MEMO INPUT button ●
- 6 FILE button ●
- 7 TIME button ●
- 8 FADER button ●
- 9 REPEAT button ●
- 10 LINE OUT LEVEL buttons ● ●
- 11 LEVEL FILE button ●
- 12 ◀▶ (manual search) buttons ●
- 13 ◀▶▶▶ (AMS) buttons ●
- 14 ■ (stop) button ●
- 15 ▶ (play) button ●
- 16 || (pause) button ●
- 17 CHECK (program check) button ●
- 18 >20 (over 20) button ●
- 19 DISC selectors ●
- 20 PLAY MODE buttons
 CONTINUE button ●
 SHUFFLE button ●
 PROGRAM button ●
 BANK button ●

Buttons with yellow letters (A, B, C,) are for writing a disc memo (page 22).

Preparing the Remote Commander

Installing Batteries

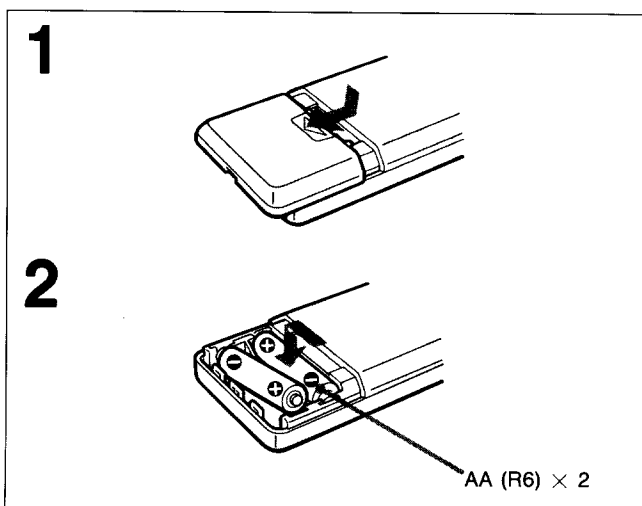

On battery life

- About half a year of normal operation can be expected when using the Sony SUM-3(NS) batteries.
- When the batteries are run down, the remote commander will not operate the unit. In this case, replace both batteries with new ones.

Notes on the remote commander and remote control operation

- Keep the commander away from extremely hot or humid places.
- Avoid dropping any foreign objects into the commander casing, particularly when replacing the batteries.
- Avoid exposing the remote sensor to direct sunlight or lighting apparatus. Such exposure can cause a malfunction.
- To avoid damage caused by battery leakage and corrosion, remove the batteries when the commander will not be used for a long time.

Setting Up the Disc Magazine

Inserting Discs into the Disc Magazine (up to 10 discs, one in each slot)

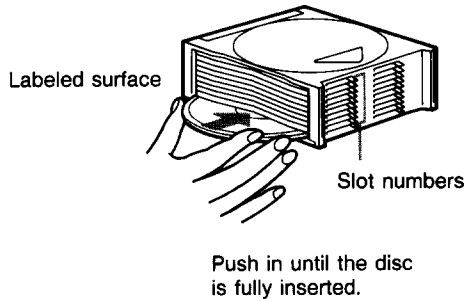

Notes

- Do not insert more than one disc into a slot.
- Each slot number corresponds to a disc number that is selected by the DISC selectors. If you select the empty slot using the DISC selectors, the circle and the selected disc number in the display will disappear.

To Remove Discs

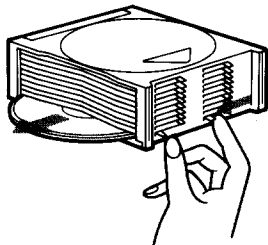

Slide the blue lever of the storage shelf in the direction of the arrow.

Notes on handling disc

- To keep the disc clean, handle the disc by its edge. Do not touch the surface.
- Do not stick paper or tape on the disc.



- Do not expose the disc to direct sunlight or heat sources such as hot air ducts, or leave it in a car parked in direct sunlight as there can be a considerable rise in the temperature.
- After playing, store the disc in its case.

Note on 8 cm (3-inch) CDs

8 cm (3-inch) CDs can be played in this unit provided that either a Sony CSA-8 adaptor, one that complies with CD standard specifications, or one that has  mark is used. Without an adaptor, or if an adaptor not recommended above is used, the unit and disc may be damaged.

NOT THIS WAY

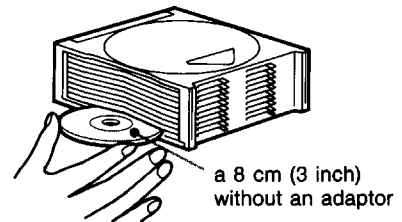

Do not insert an empty adaptor as it will become lodged in the unit and cannot be removed without special equipment.

NOT THIS WAY

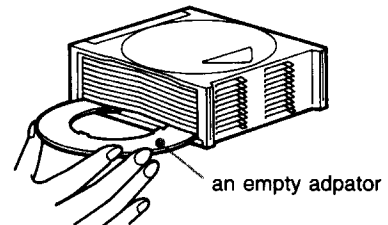

Playing a Disc – Continuous Play

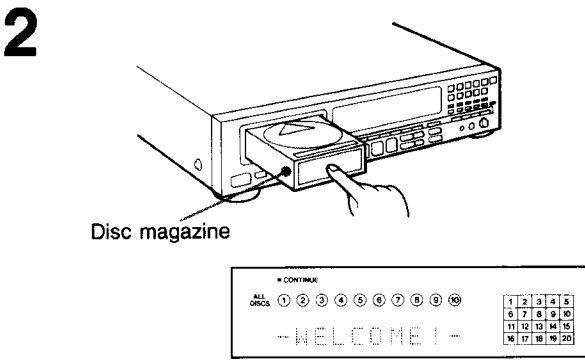
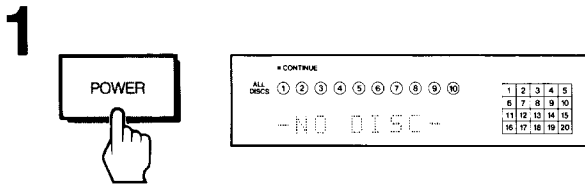
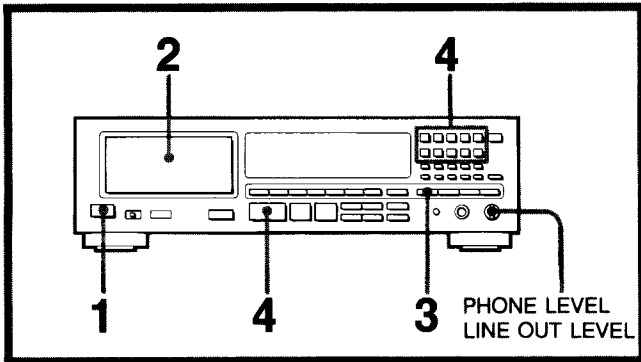

The “- WELCOME ! -” display only appears after loading a magazine.

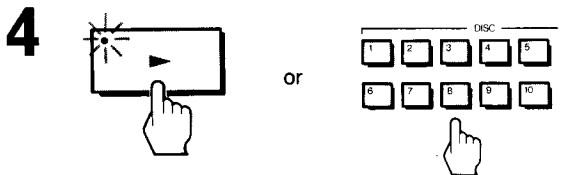
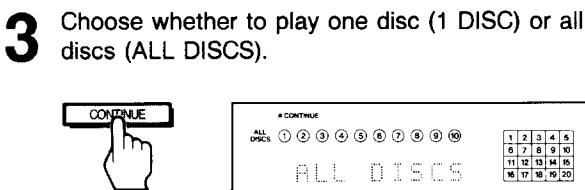

When all selections of a disc are played, the circle on the tray number goes off.

Before playing a disc, turn on the amplifier and set the input selector to the CD player position.

To stop play

To stop for a moment during play, press **II**.

Press **▶** or **II** to resume play.

To stop play, press **■**.

To stop play and remove the disc magazine, press **▲** EJECT.

Caution on adjusting volume

Do not turn up the volume while listening to a portion with very low level inputs or no audio signals. If you do, the speakers may be damaged when a peak level portion is played.

To listen with the headphones

Connect the headphones and control the volume with PHONE LEVEL/LINE OUT LEVEL control or LINE OUT LEVEL buttons on the remote commander.

Notes

- Disc memo (see page 22) appears in the display window during the stop mode. If the disc memo is not stored, the disc number – such as “*DISC-1*”, is displayed.
- When a magazine is loaded, all slot numbers will be displayed until that slot is recognized as empty. Empty slots are recognized when **▶** is pressed. The corresponding numbers will disappear.
- “- NO DISC -” is displayed when the magazine is not loaded in the unit, or when the magazine is empty. You can change the “- NO DISC -” display. See page 22 for procedure.
- The play mode in use before turning the power off is retained in memory.

About the “- SEE YOU ! -” display

The “- SEE YOU ! -” display only appears after ejecting the magazine. A few seconds later, the display will change to “- NO DISC -”.

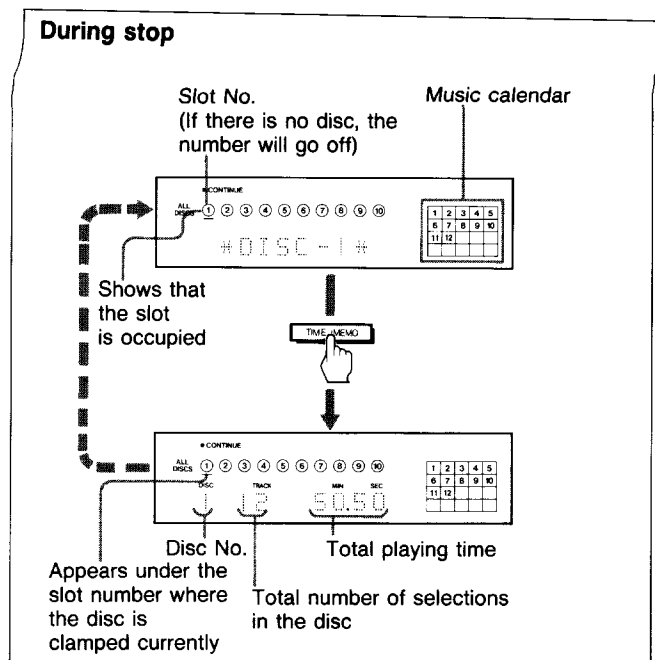

Information Display

Choose a disc to play with the DISC selectors. If you press **■** while the bar under the disc number is blinking, the total number of selections and total playing time will appear after the bar stops flashing. In a few seconds, the display will change and show the disc number or if there is one, the disc memo. This display sequence is also available when using the DISC SKIP. When the DISC SKIP button is pressed the disc number or, if applicable, the disc memo will appear until that disc is set.

To activate this display sequence while the disc number or disc memo is being shown, press the TIME/MEMO button.

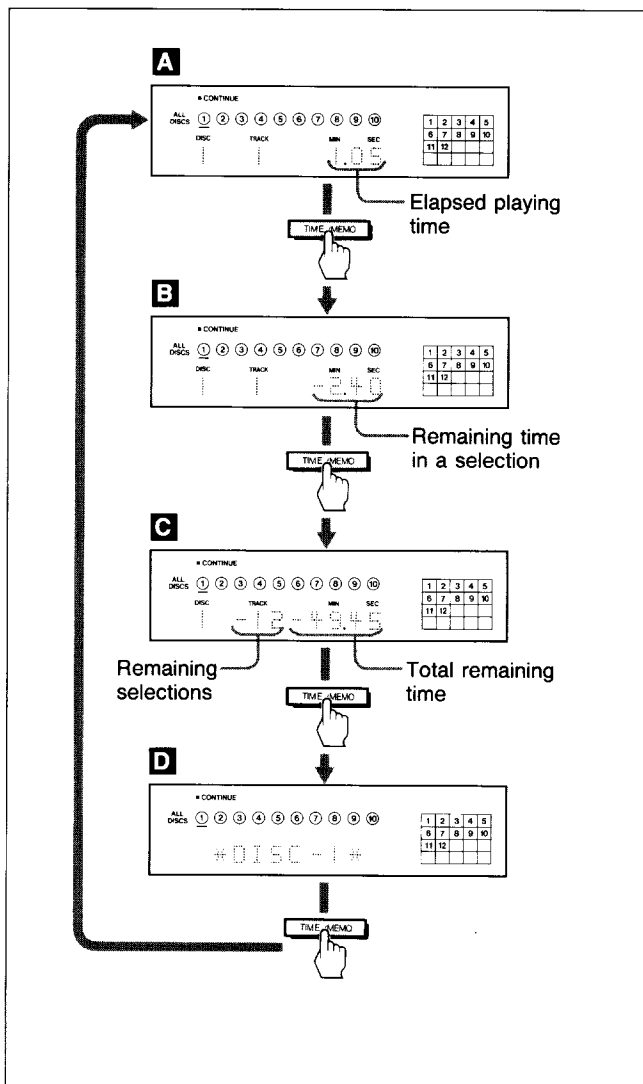

If you press TIME/MEMO during play, the display changes to give you the following information:

- A** Elapsed playing time of the selection. It automatically displayed when play begins.
- B** Remaining time in a selection. Selection numbers up to 20 are also displayed at the bottom of the display window. If the track number is larger than 20, “-.-.-” appears instead of the remaining time display.
- C** Remaining time and remaining selections of the disc (displayed only in the continue mode). When the time fade function is activated, remaining time and remaining selections until the fading out will be displayed.
- D** Disc memo or disc number.

Notes

- Total remaining time is only available during continuous mode. It will not be displayed by pressing the TIME/MEMO button during program, bank or shuffle mode.
- Total remaining time will be displayed, if time fade is set during all play mode.

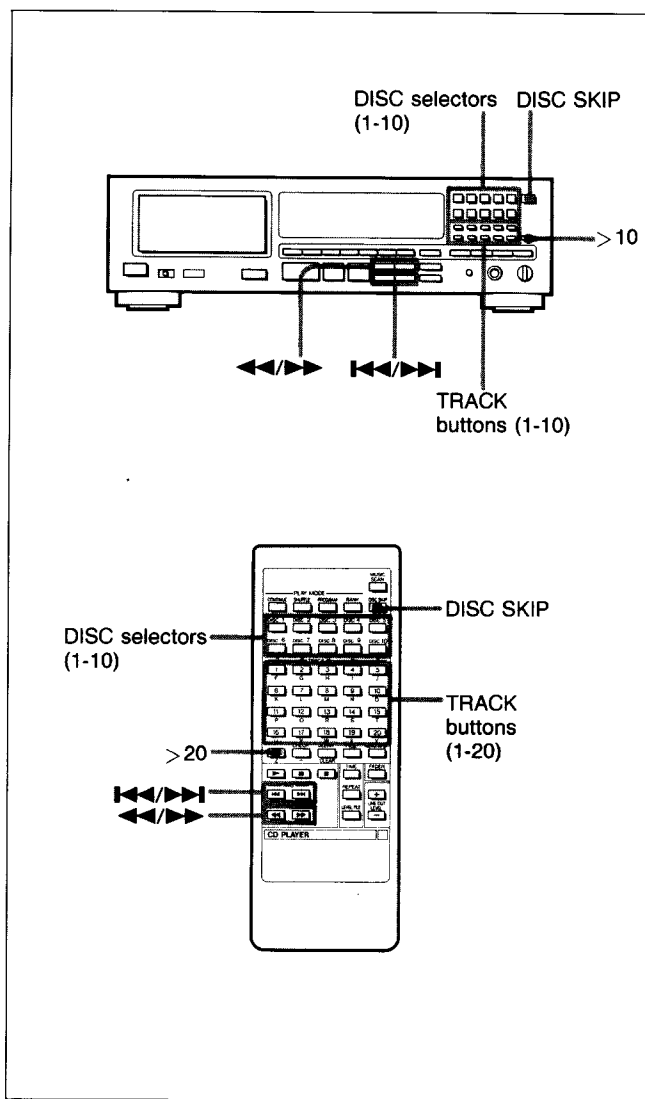

Selecting a Desired Disc

By using the DISC selectors or the DISC SKIP button during play, you can locate the beginning of any disc.

To select a particular disc	Press the corresponding DISC 1 to 10 button.
To change to the disc next to the current one	Press DISC SKIP.

Locating a Particular Selection

Locating a selection in sequence (Automatic Music Sensor)

You can locate the beginning of a selection on the disc being played.

To locate the beginning of the selection being played	Press ⏮ once.
To locate the beginning of the next selection	Press ⏭ once.

Continue to press until the selection you wanted has been located.

To locate directly

Press one of the TRACK buttons to enter the desired selection number.

- **1** to **10** on the main unit.
To enter a number greater than 10, use the **>10** button.
 - **1** to **20** on the remote commander.
To enter a number greater than 20, use the **>20** button.
- e.g. To play from selection No.22
Press **>10** **2** **2** or **>20** **2** **2** .
To play from selection No.30
Press **>10** **3** **10** or **>20** **3** **10** .
10 functions as the figure 0.

Locating a Particular Point in a Selection

You can locate a particular point in a selection during play.

To search quickly while monitoring the sound

To go ahead at high speed

Keep **⏭** pressed during play and release at the desired point.

To go back at high speed

Keep **⏮** pressed during play and release at the desired point.

To search quickly by observing the display

Press **⏏** then keep **⏭** or **⏮** pressed. The search speed will increase, but there will be no sound. Find the desired point by observing the display. Press **⏭** or **⏏** again at the desired point.

If you continue to press **⏭**

If you continue to press **⏭** once the end of the disc has been reached, “- OVER -” appears in the display window. Press **⏮** or **⏏** to return to the normal display.

Playing in a Random Order – Shuffle Play

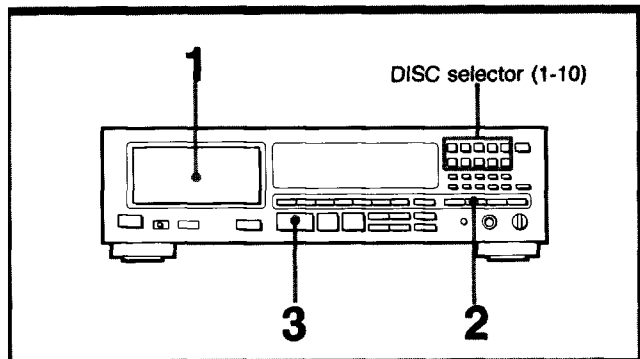

1

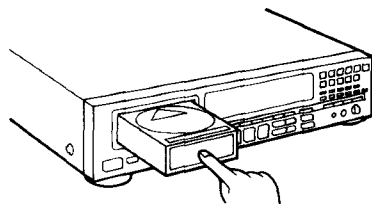

2 Choose whether to play one disc (1 DISC) or all discs (ALL DISCS).

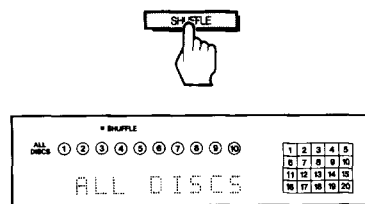

3

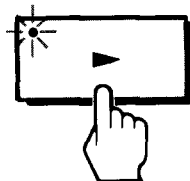

When all selections of a disc are played, the circle on the tray number goes off.

You can have the selections played in a random order. The unit will play all the discs or just disc(s) you desire. Once a selection is played, it will not be played again until the random order is completed.

To stop play

Press ■.

To cancel shuffle play

Press CONTINUE and return to the continuous playing mode.

To select a desired disc during "1 DISC" shuffle play

Press the desired DISC 1-10 buttons. A circle will appear around the selected disc.

To Play Only the Desired Discs in a Random Order – Select Shuffle Play

You can select the desired discs during the stop and play modes. (ALL DISCS mode)

To select the desired discs

Press the DISC 1-10 buttons. Circles appear around the selected disc numbers to be played.

To delete a disc which you have selected, press the applicable DISC 1-10 buttons. The circle around the selected disc number will disappear.

You cannot put off a circle around the number of the disc being played.

If you press SHUFFLE during play (except for shuffle play)

Shuffle play begins from the current selection.



What is this indication?

This indication appears while the player is shuffling the selections.

Note

Only the first 48 selections of a disc that contains more than 48 selections will be played in "ALL DISCS" mode. In "1 DISC" mode up to 99 selections of a given disc can be played.

Playing Repeatedly – Repeat Play

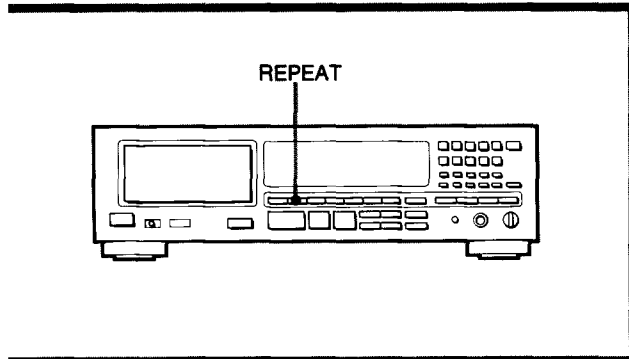

Press before or during play.



"REPEAT" appears. The unit repeats the current playing mode. To repeat a single selection, press REPEAT again during repeat play of the continuous playing mode. "REPEAT 1" appears.

Repeat play can be used in any play mode to repeat a single disc or all discs in the unit. In the continuous play mode, you can repeat a single selection.

Playing mode	Selections played
Continuous play (ALL DISCS)	All the selections on all discs, or the selection currently being played (REPEAT 1)
Continuous play (1 DISC)	All selections on the disc currently being played, or the selection currently being played (REPEAT 1)
Shuffle play	All selections on the disc (in the 1 DISC mode) or all discs (in the ALL DISCS mode) are reshuffled.
Select shuffle play	All selections on a selected disc are reshuffled.
Program play	Repeats all selections and/or programs in their programmed order.
Bank play	Repeats all selections stored in the bank in their programmed order (or all selections if the disc does not have a bank file).

To cancel repeat play

Press REPEAT again.

"REPEAT" disappears.

To cancel repeat play of the continuous play, press REPEAT twice. "REPEAT 1" disappears.

Playing in a Desired Order – Program Play

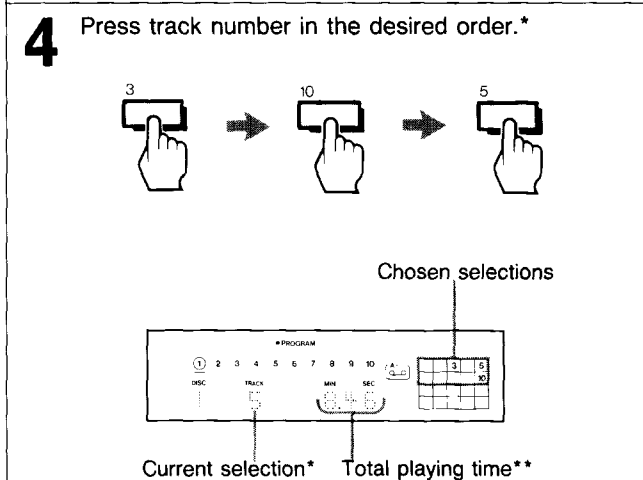
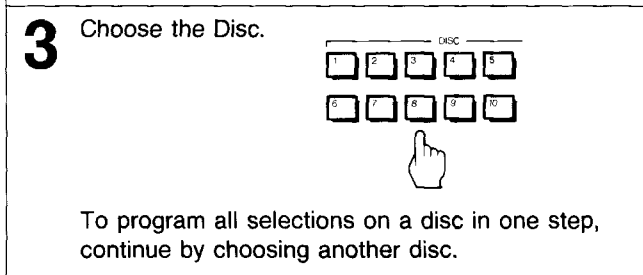
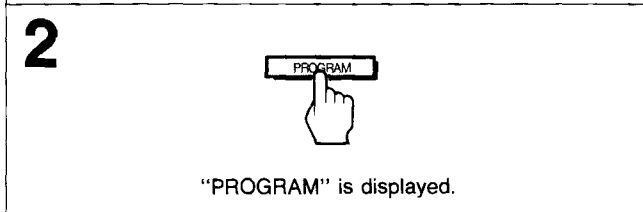
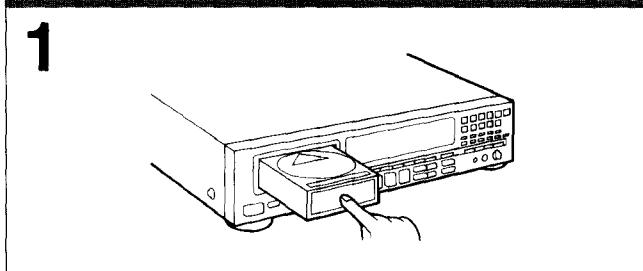
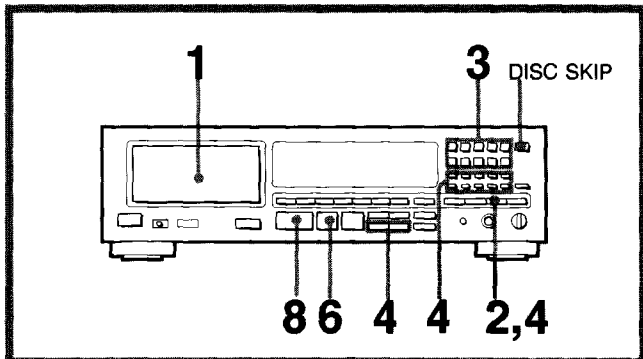

If you have programmed a selection number over 20, numeric of STEP is displayed instead of the total time.

* To choose a selection number over 10 (or 20), see page 11.

Designating the Playing Time – Program Edit

A Choose selection and check the time.

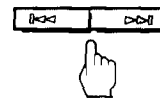

Press **◀▶** repeatedly to choose an appropriate selection.

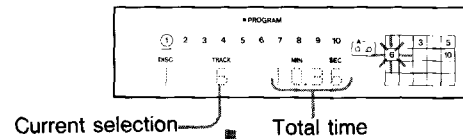

B A satisfactory selection has been chosen.

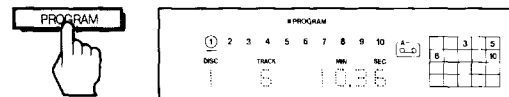

The selection is stored, and the flashing numbers in the window lights up.

5 To program additional selections from the same disc, repeat step 4.
To program additional selections from another disc, repeat steps 3 and 4.

6 If you program the selections for side B, insert a pause.

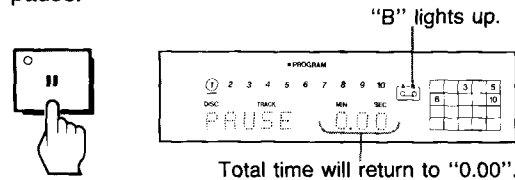

7 Program the selections for side B.
Repeat steps 3 to 4.

8 The selections for side A will start playing.

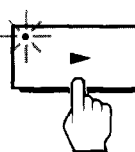

** It may take time for the total playing time of the program to appear. Also, if the total playing time exceeds one hour, the current selection indication will be used to display the hour unit.

You can make a program by designating up to 32 selections in the order you want them to be played. The unit will play the disc according to your program.

You can make a program for both sides (side A and side B) of the tape at one time.

You can program one selection or one disc in a step.

To play the selection for side B

When the selections for side A have been played, the unit will pause. ("B" will light up.)

Set the tape to the beginning of side B, then press ► or ■. The selections for side B will start playing.

Adding selections to a program during program play

- 1 Press the desired disc button while the unit is in the play or pause mode.
- 2 While the step display appears, press the TRACK buttons which correspond to the selection number you want to add.

To stop program play

Press ■. The last selection number programmed is displayed.

To resume play, press ►. Play begins from the beginning of the program.

You can play the same program repeatedly as long as you do not cancel program play or erase the program.

To cancel program play

Press CONTINUE and return to the continuous playing mode. The program will be erased.

Skipping to the next selection programmed

Press ►► during play.

Going back to the beginning of the selection being played

Press ◀◀ during play.

Display on step 3 (procedure step display):

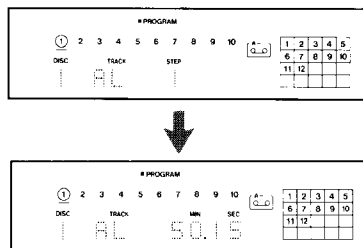

Checking the Programmed Selections

Press CHECK

The disc, track, and program numbers of the first selection in your program will be displayed.

Each time you press CHECK, the next selection in the program will be displayed. When CHECK is pressed after the last selection, "-END-" appears and then the display returns to the initial display.

Clearing the Programmed Selections

Clearing the whole program

Press ■ once during stop, or twice during play. All the selections will be cleared.

Clearing the last selection in a program

Press CLEAR during stop.

The last selection will be cleared each time CLEAR is pressed.

Clearing a specific selection

- 1 Press CHECK repeatedly until the selection to be cleared is displayed.
- 2 Press CLEAR while the selection number is displayed. The selection will be cleared from the program.

The whole program will also be cleared in the following situations

- ▲ is pressed.
- Power is turned off.
- Select other play modes.

To check the step of programmed selections

Press TIME/MEMO during stop mode.

The number of programmed selections will be displayed for few seconds in the window.

To check the remaining time of the selection being played

Press TIME/MEMO once to see the remaining time of the selection being played; twice to see the disc memo or disc number; three times to return to the initial display.

The total remaining time cannot be displayed.

If you have programmed a selection number over 20, --- is displayed instead of the remaining time.

Note

When selections have been programmed for sides A and B, the total playing time displayed during stop mode will show the selections programmed for side B and the total playing time for side B.

Designating the Total Playing Time – Time Edit

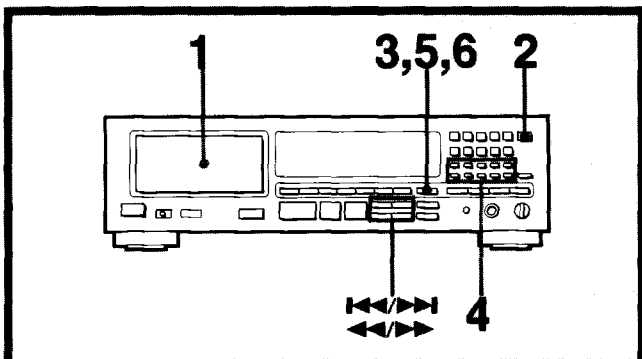

1

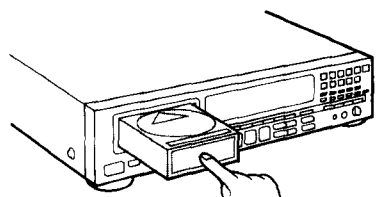

2 Choose the Disc.



Make sure that the total number of selections and the total playing time are displayed. Then proceed as follows in the stop mode.

3



"EDIT" light up.



Brinking

4 Designate the length of one side of your tape.
Example: a 46 minute tape
(23 minutes per side)

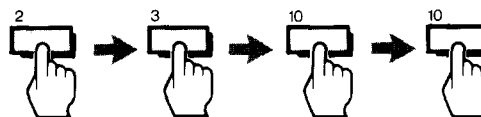

Time

Press [10] for "0"

You need not press keys for seconds, unless required.

You can designate the tape length easily with the **⏮/⏭** buttons. Each time you press a button, the time changes in the following way.

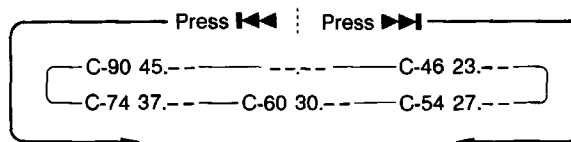

To set the seconds, press **⏮/⏭**. The time increases or decreases by 10 seconds.

5



The program for side A is completed.
If "LINK" blinks, see "To add selection(s)".

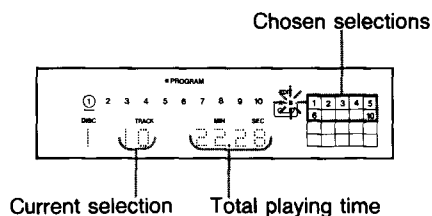

6 Press EDIT/TIME FADE once more, to make a program for the other side of your tape. If "LINK" blinks, see "To add selection(s)".

Note

Total playing time can be set from 10 seconds up to 59 minutes 59 seconds.

You can designate a time and the unit will make 2 different programs of selections each fitting within that period. Use this function, by designating the length of your tape, for editing both sides of a tape.

To add selection(s) — LINK —

After all selections on the disc have been programmed, if there is selection(s) within the remaining time, "LINK" and the selection number(s) will blink.

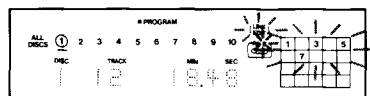

To add selection, press the numeric button for the selection number or press the EDIT/TIME FADE again. When pressing the EDIT/TIME FADE, a program will be made automatically to fit the playing time as close as possible to the remaining time.

If the remaining time can contain other selection(s), "LINK" and the selection number keep blinking. When "LINK" blinks, if the disc is changed by another disc, the new selection number(s) on the new disc that fit in the remaining time will blink.

"EDIT" disappears when the playing time becomes equal to the designated time. Whether "LINK" is blinking or not, you can change the disc by another disc and choose selection(s) to fit the remaining time.

To cancel the "EDIT" display in the window, press the ■ button.

To play the program

Press ►.

The selections for side A will be played and then the unit will pause. "B" lights up in the tape side indicator. Set the tape to the beginning of side B, then press ► or ■■.

The selections for side B will be played.

Note

Playback can be performed when "EDIT" is displayed.

To stop playing

Press ■.

You can play the same program repeatedly as long as you do not erase the program.

To cancel time edit

Press CONTINUE and return to the continuous playing mode.

The program will be erased.

To erase the entire program

Press ■ once during stop; twice during play.

Press ■ twice when "EDIT" appears in the display during the stop mode.

The program is also erased, when you turn off the unit or press ▲.

To include desired selections in the program

1 Make your own program of the desired selections.

See page 14 for instructions.

2 Follow the procedure as shown on the preceding page.

Just designate the length of your tape; you need not subtract the length of your program. The unit will place your selections at the beginning of its program and add other selections to fit the remaining time.

Checking the programmed selection

See page 15.

To designate a different time for each side

Execute steps 1 to 4 and press ■■. Then repeat steps 2 and 4.

Do not execute step 5.

If your disc has more than 20 selections

- Selections over 20 cannot be programmed with the time edit function.
- If the program already contains a selection over 20, the time edit function will not work.

Notes

- Up to 32 steps will be programmed. Furthermore, the time edit function cannot be used if your program has 32 steps.
- Time edit will not work for programs with total playing times exceeding one hour.

Convenient Features for Tape Recording

The following functions are convenient for editing your own tapes.

Time Fade and Fade in/Fade out cannot be operated when the DIGITAL (optical) OUT is used for connections.

Fading in/Fading out

You can have the play fade in and fade out between 2-10 seconds.

When no time is specified, the play will fade in and fade out for 5 seconds.

To set the fade time

- 1 Press ■.
- 2 Press FADER. "FADE 5 SEC" will appear in the display window. The actual fade time "5" will be flashing.
- 3 Press ◀◀/▶▶ to select fade time between 2-10 seconds.
- 4 Press FADER.

To end the play fading out

Press FADER when you want to start fading out.

 flashes in the window, and play fades out and unit enters the pause mode.

To restart the play fading in

Press FADER in the pause mode.

 flashes in the window, and play fades in.

Fading out after a desired duration – Time Fade

You can have the play fade out at the end by designating the play duration. Once time fade is set, it functions twice for editing both sides of a tape. You can change discs without canceling this function. The fade time is preset to 5 seconds, but you can change it between 2-10 seconds.

To set time fade

- 1 Press EDIT/TIME FADE twice during stop.

 is displayed in the window.

- 2 Set the desired play duration, using numeric buttons.

e.g. To set to 27 minutes, press **2** **7** **10** **10** .

You need not press buttons for seconds, unless required.

You can designate the tape length easily with the ◀◀/▶▶ buttons. Each time you press a button, the time changes in the following way.

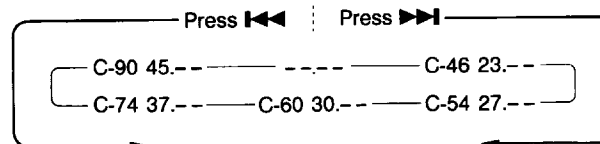

To set the seconds, press ◀◀/▶▶. The time increases or decreases by 10 seconds.

Note

The desired play duration can be set from 10 seconds up to 59 minutes 59 seconds.

- 3 Press EDIT/TIME FADE.

- 4 To start play, press ▶.

After the designated time, play fades out and pauses.

Tape side B lights up. Press ■ or ▶ to resume playing for the other side of the tape. If you press FADER, fade in will start. When the play fades out for the second time, the unit pauses and the time fade function is canceled.

When playback ends in the duration of time fade

Time fade function will be kept on. Change the disc and start playback automatically when the total playing time is within some seconds before the designated time, the player fades out.

To cancel time fade

Time fade will be canceled when

- EDIT/TIME FADE is pressed once again.
- ◀◀/▶▶ (manual search) is pressed during play.

To display the time remaining until the time set

Press TIME/MEMO twice.

If the P.SEARCH is pressed after setting time fade, time fade is released but peak search is kept active.

Locating the loudest portion of the disc – Peak Search

This unit can search a disc from the beginning to the end and determine the loudest portion (peak level) of the disc, and then play that portion repeatedly. This function will make it easier for you to adjust to the optimum level when recording on tape.

This function operates in all play modes as follows:

Play mode	Operation
Continuous and shuffle modes	Searches all selections on the disc that is currently clamped.
Program mode	Searches all programmed selections
Bank mode	Searches all programmed selections on the disc that is currently clamped.

Unless you are using the program mode, the unit will scan all discs that are clamped, even in the ALL DISCS mode.

To activate the peak search

Press P.SEARCH during the stop mode.

“PEAK” flashes in the display and the all selection of the disc or program will be searched automatically. After finishing the search, “- PEAK -” is displayed and the loudest portion is played repeatedly for 4 seconds.

Note

To go to another disc press DISC SKIP button during stop.

To start play immediately

Press ►. The play starts from the beginning of the disc.

To stop the peak search

Press ■.

Press || to pause at the first selection.

Note on peak search function

The unit determines the loudest portion (peak level) of a disc by searching it at fixed intervals. As a result, the portion searched may differ from the actual peak level. In addition, this function may determine different portions as the peak level for the same disc. However, the difference between the portion searched and the actual peak level is insignificant and will not present any problem in adjusting the recording level.

Playing the Beginning of Each Selection – Music Scan

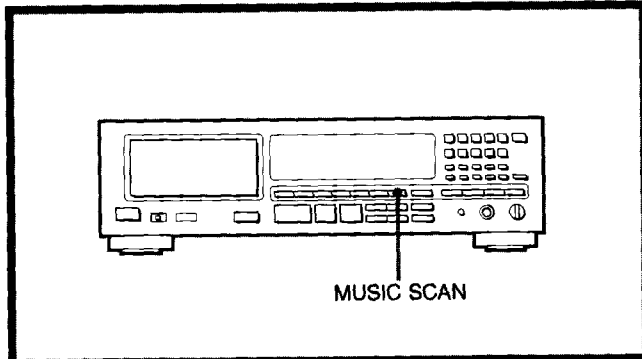

MUSIC SCAN

Press during stop.



To change the playing time

Press MUSIC SCAN again.

Each time you press MUSIC SCAN, the display will be as follows:

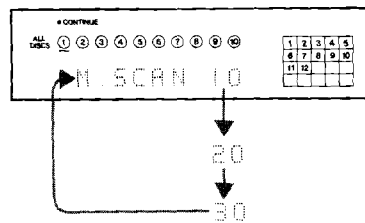

The indicator on the ► button blinks and beginning of each selection is played for 10, 20 or 30 seconds as designated and fades out.

You can check the selections by scanning the beginning of each selection on the disc. When "ALL DISCS" is selected in continue mode, the first selection of each disc will be scanned.

You can use this function in any play mode.

When scanning is finished,
the unit enters the stop mode.

To stop music scan play

Press ■.

Starting play at the selection being played during music scan

Press ►. The indicator on the ► button will light up.

Notes

- Programmed pauses in program mode will be disregarded during music scan play.
- If you press the ◀◀/▶▶ button, music scan will be canceled.
- Pressing the MUSIC SCAN button while the beginning of selection is being scanned will extend the playing time for 10, 20, or 30 more seconds.

On Custom Files

The CD player is equipped with a memory which allows you to store three types of information called "custom files".

Up to 184 discs of Custom File can be retained in the unit's memory.

The three custom files you can store in memory

Disc memo	To store a name of up to 10 letters for an individual disc. (page 22)
Bank	To store a program in memory so it can be played again. (page 24)
Level file	To preset an output level of the headphones/variable line out jacks for an individual disc. (page 25)

What is this Indication?

CF MEMO BANK LEVEL

Lights when Level file is memorized.

Lights when Bank is memorized.

Lights when Disc Memo is memorized.

Memory backup for the custom files

Custom files, once memorized, are retained in the compact disc player's memory for approximately 1 month without AC power supply.

Since the memory is stored in the unit and not on the disc, you cannot perform custom file functions with the same disc on a different player.

What is this Indication?

FILE FULL

This indication appears when FILE is pressed while no custom file can be memorized for the disc currently put in the player. To make a custom file for the disc, clear the custom file of another disc.

To clear custom files of all discs at once

Without loading the disc magazine, press POWER to turn on the unit while keeping ERASE and FILE pressed. "ALL ERASE" will be displayed and all custom files are cleared.

To check the items of the custom files

Press TIME/MEMO (while "-NO DISC-" is displayed) without the disc magazine loaded. Each time you press TIME/MEMO, the items of the custom files and the items of the each column of **CF MEMO BANK LEVEL** about the disc are displayed. If you press TIME/MEMO when the last disc's information is displayed, "-END-" is displayed and returns to "-NO DISC-" after a few seconds. To clear all custom files for a single disc, press TIME/MEMO repeatedly until the undesired custom file is displayed. Then press ERASE. "FILE ERASE" is displayed and **CF MEMO BANK LEVEL** goes off in the display window.

Assigning Names to a Disc – Disc Memo

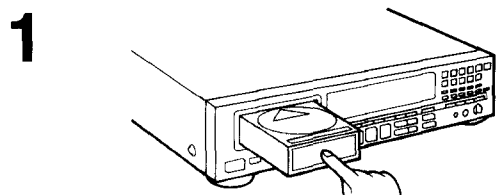
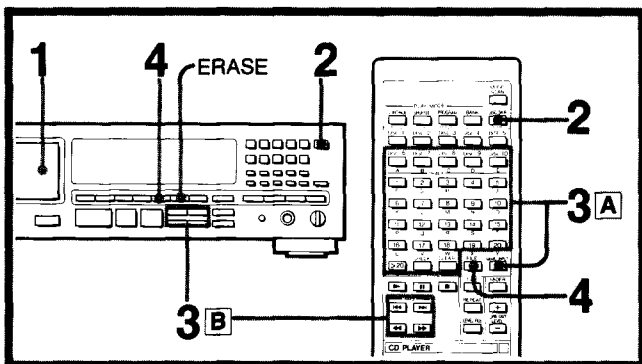

2 Choose the disc.



Make sure that the total number of selections and the total playing time are displayed. Then proceed as follows in the stop mode.

3 A Using the MEMO INPUT button with the letter buttons on the remote commander (This function can be entered while playing)

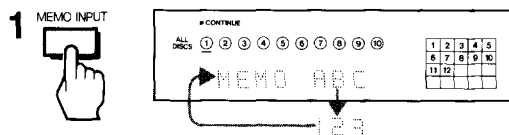

Each time you press MEMO INPUT, the display changes as shown above. Choose the desired capital letters, or numbers.

2 Press the applicable letter button.

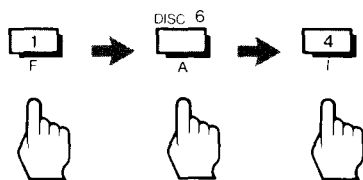

Move the cursor to select the next letter.

To change to numbers, return to the step **A** -1.

B Using the ◀▶ buttons

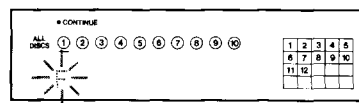

Press ◀ or ▶ until the desired letter appears.

Example: if ▶ is pressed 7 times, F appears.

2 When the desired letter appears, press ▶.

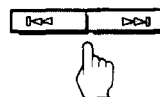

Move the cursor to select the next letter.

Repeat steps **B** -1 and **B** -2.

4

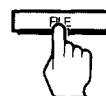

Lights up.



After about 1 second, the memo you have written will be displayed.

Each time the disc is put in the unit, the memo will be displayed.

Note

Symbols cannot be entered with the letter buttons on the remote commander. To enter symbols, use ◀▶ buttons.

Using the disc memo function, you can assign a name within 10 letters for each disc. The memo appears in the window every time you put the disc in the player.

One name can be assigned for one disc.

When the magazine is not loaded in the unit, you can also assign a title for the “- NO DISC-” display (see page 9) using the same procedure as that for the disc memo.

Usable letters and symbols

For the disc memo, 46 letters and symbols and a space can be used. When the ◀◀/▶▶ button is pressed for the first time, the space appears. Each time ▶▶ is pressed, letters and symbols will appear in the following order.

(space) A B C D E F G H I J K L M N O P Q R S T U V W X Y Z ' & . < > * / + 9 8 7 6 5 4 3 2 1 0 -
--

Use ◀◀ to call up a previous character.

To rewrite letters or symbols

Before pressing FILE

Move the cursor under the letter/symbol to be changed and then select the desired letter/symbol using ◀◀/▶▶ or letter buttons on the remote commander.

To erase the letter and make space, locate the desired place with ◀◀ ▶▶ and press CLEAR.

After pressing FILE

Repeat from step 2.

Note

Disc memos can also be changed while playing a disc by pressing the MEMO INPUT button on the Remote Commander.

Displaying the Memos

To display the memo for the disc being played

Press TIME/MEMO twice during the shuffle, program or bank mode and three times during the continuous mode. To return to the normal display, press TIME/MEMO once more.

Clearing the Disc Memo



- 1 Load the magazine with the disc that has the disc memo you want to clear. Insert the magazine and choose that disc with the DISC selectors or the DISC SKIP button.
- 2 When the disc memo appears, press ◀◀/▶▶ or MEMO INPUT on the remote commander. The blinking cursor will appear.
- 3 Press ERASE. “FILE ERASE” is displayed and “CF MEMO” goes off from the display window.

Keeping the Program in Memory – Bank

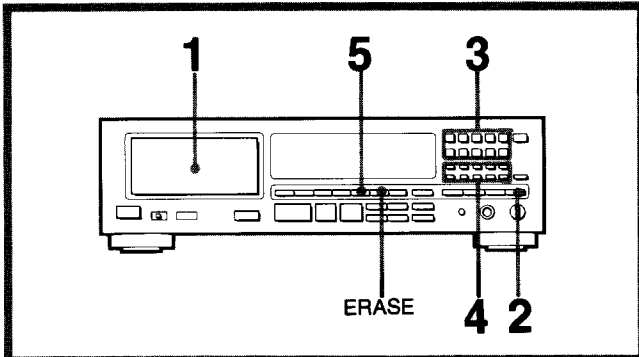

1

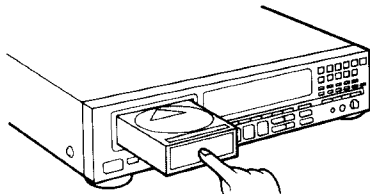

2



Press BANK and the "BANK" indicator will turn on.

3

Choose the disc.

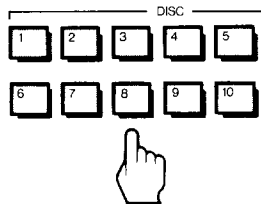

4

Program the selections as your desire. (See page 14) Press BANK instead of PROGRAM for steps 2 and 4.

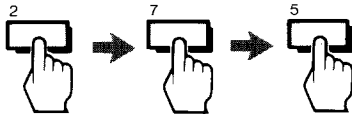

5



Lights up

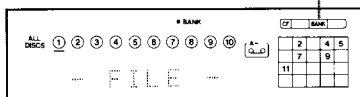

("- FILE -" will disappear approximately one second later.)

After programming selections, you can keep the program memorized, so that the disc is played always in the fixed order. The memorized program is called "bank."

Memorizing a Bank

The program is stored into the memory. (One disc can memorize up to 24 programs.) Only one bank can be made for a disc.

Notes

- You cannot program a whole disc under a single program number.
- To pause during the bank play, press **II** instead of step 4.
- If you press a DISC 1-10 buttons during the stop mode, the bank stored for the disc is displayed.

Playing the Disc Using the Bank

- 1 Insert discs into the magazine and set the magazine into the unit.
- 2 Press BANK to choose whether to play "1 DISC" or "ALL DISCS".
- 3 If you have any disc that you want to play before playing the bank, or if you want to play in the 1 Disc mode, choose the applicable disc.
 appears in the display.
- 4 Press **▶** to start play. When playing in the ALL DISCS mode, any disc without a bank file will be played in its entirety.

Clearing the Bank



- 1 Load the magazine with the disc that has the bank you want to clear. Insert the magazine and choose that disc with the DISC selectors or the DISC SKIP button.
- 2 Press BANK.
- 3 Press ERASE.
 "FILE ERASE" is displayed and "CF BANK" goes off from the display window. The bank is cleared.

Set the desired Output Level to a Disc Level File

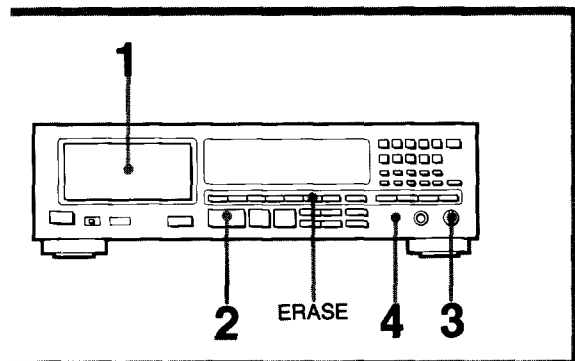

Using the level file function, you can preset the desired output level for each disc. When a disc with the level file is played, the PHONE LEVEL/LINE OUT LEVEL control on the front panel is automatically adjusted to the preset level.

When you use the level file function, use headphones or the amplifier connected to the variable line output jacks. This function does not work for the output level of the fixed line output and optical digital output jacks.

To preset a new level on to the current level file
Repeat steps 3 and 4.

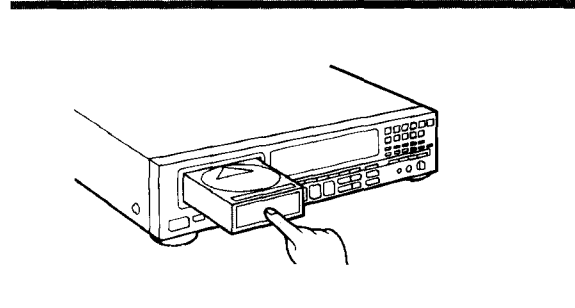

Clearing the Level File



- 1 Load the magazine with the disc that has the level file you want to clear. Insert the magazine and choose that disc with the DISC selectors or the DISC SKIP button.
- 2 Press LEVEL FILE. "LEVEL FILE" appears in the display.
- 3 Press ERASE while the "LEVEL FILE" is displayed. "FILE ERASE" is displayed and "CF LEVEL" goes off from the display window. The level file setting is cleared.

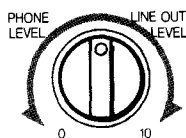
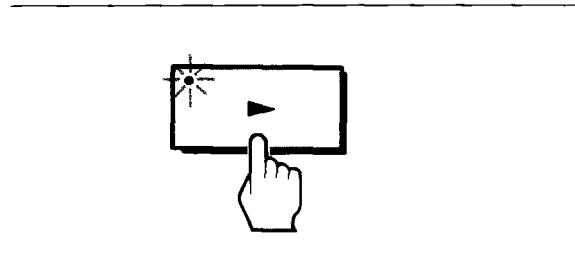

Adjust the level. You can also use LINE OUT LEVEL buttons on the remote commander.

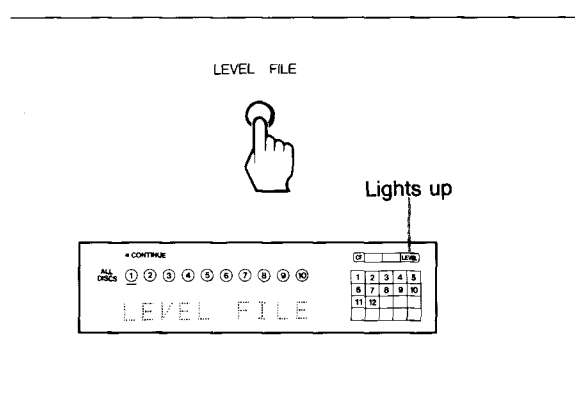

Troubleshooting Guide

The following checks will help you correct most problems which you may encounter with your unit. Before going through the check list below, refer to the connections and operating procedures.

Should any problem persist after you have made these checks, consult your nearest Sony service facility.

Symptom	Cause	Remedy
Play does not start.	Dirty disc	Clean the disc.
	The disc is inserted with the label surface downward.	Insert the disc with the label surface up.
	The unit is in the pause mode.	Press the ► or ■ button to release pause.
	Moisture condensation	Wait for approx. one hour after turning on the unit then start play.
No sound	Loose connection	Connect the cords firmly.
Display window does not illuminate even when the power is turned on.	The AC power cord is disconnected.	Connect the AC power cord firmly.
Remote commander does not operate the unit.	The batteries are exhausted.	Replace both batteries.
	The remote commander is not pointed at the remote control sensor.	Point the remote commander to the sensor.
	There is an obstacle between the remote commander and the unit.	Remove the obstacle.
	The remote commander is too far from the unit.	Move closer.
The disc magazine cannot be removed even if the ▲ button is pressed.	The power of the unit is not turned on.	Depress the POWER switch (ON).
	The ▲ button is not pressed firmly.	Press the button again.
Any operation is not possible.	The internal control program may not run.	Turn off the power and turn it on again.

Note

This unit uses several micro-computer chips to control a series of operations. Sometimes, an operation may not work properly due to the condition of the power being supplied. In this case, turn the power off, then turn it back on and retry the operation.